

X-Control

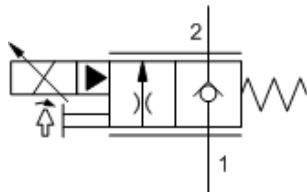

E-Control

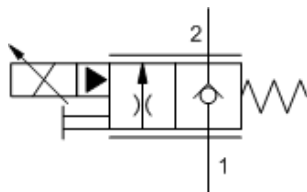

M-Control

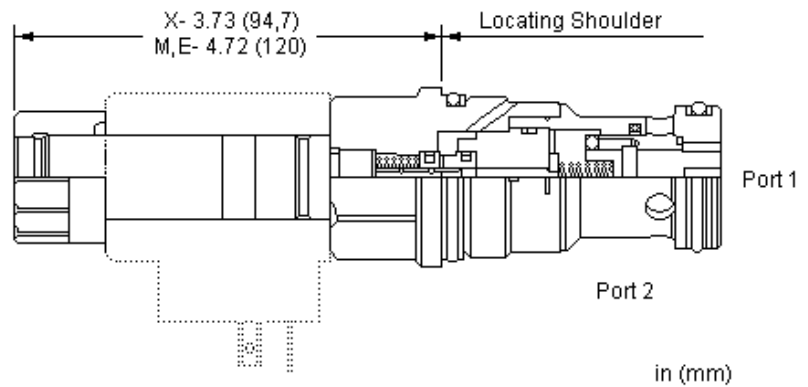

This valve is a pilot-operated, normally closed, electro-proportional throttle with reverse free-flow check. Energizing the coil generates an opening force on the pilot stage which vents the main stage poppet to open proportionally. Metered flow is from port 1 to port 2 with reverse free flow from port 2 to port 1.

TECHNICAL DATA

NOTE: DATA MAY VARY BY CONFIGURATION. SEE CONFIGURATION SECTION.

Recommended dither frequency	100 Hz
Maximum Valve Leakage at 110 SUS (24 cSt)	20 drops/min. @5000 psi
Manual Override Force Requirement	33 N/100 bar @ Port 1
Deadband, nominal (as a percentage of input)	25%
Manual Override Stroke	1,50 mm
Seal kit - Cartridge	Buna: 990016007
Seal kit - Cartridge	EPDM: 990016014
Seal kit - Cartridge	Polyurethane: 990016002
Seal kit - Cartridge	Viton: 990016006

CONFIGURATION OPTIONS

Model Code Example: FPHKXCN

CONTROL	(X) FLOW RATE	(C) SEAL MATERIAL	(N) COIL *
X No Manual Override	C Nominal 40 gpm @ 200 psi (14 bar) differential (160 L/min.)	N Buna-N	No coil
E Twist (Extended) Manual Override	A Nominal 20 gpm @ 200 psi (14 bar) differential (80 L/min.)	E EPDM	212 DIN 43650-Form A, 12 VDC
M Manual Override	E Nominal 60 gpm @ 200 psi (14 bar) differential (240 L/min.)	V Viton	224 DIN 43650-Form A, 24 VDC
			712 Twin Lead, 12 VDC
			724 Twin Lead, 24 VDC
			912 Deutsch DT04-2P, 12 VDC
			924 Deutsch DT04-2P, 24 VDC

* Additional coil options are available